

AN OVERVIEW OF ELECTRICAL CODE REQUIREMENTS

Article 525 of the National Electrical Code covers the installation of portable wiring and equipment for carnivals, circuses, exhibitions, fairs, traveling attractions, and similar functions, including wiring in or on all structures.

It is the responsibility of each exhibitor or user of electrical equipment to make arrangements for an electrical inspection.

110.3 Electrical Equipment. All electrical equipment shall be listed and labeled. Equipment shall be installed and used in accordance with that listing. Damaged or defective electrical equipment shall be repaired or replaced.

525.21 Disconnecting Means. A means to disconnect each portable structure from all ungrounded conductors shall be provided. The switch shall consist of no more than six enclosed switches or circuit breakers and shall be located within sight of and within 6 feet of the operator's station. Fuse-holders with switches mounted on box covers and switch controlled multi-outlet strips are not acceptable as the required disconnecting means. Enclosures for disconnect switches and circuit breakers installed outdoors must be rainproof unless otherwise protected from the weather by location. Where accessible to unqualified persons, the disconnecting means shall be lockable.

525.20 Portable Cords. Portable cords shall be size 12 or larger Type G, PPE, S, SE, SEO, SEOO, SC, SCE, SCT, SO, SOO, ST, STO, STOO, W or other types identified for extra-hard usage, and must be of the grounding type. The cord type is printed or embossed on approved cords. Two-wire cords are not allowed. Cables with a "J" in the type designation (such as Type SJT) are junior-hard-service rated and are not permitted where subject to physical damage. When used outdoors, cords shall be listed for wet locations and be sunlight resistant, unless they are an integral part of listed portable equipment. All cords shall be continuous and contain no splices. Repair of the cord outer jacket only may be done with heavy-wall heat-shrink tubing with proper adhesive or by a vulcanizing process.



525.6 Mechanical Protection. Wiring in and on rides, concessions and other units shall be provided with mechanical protection where subject to physical damage. Flexible cords and cables run on the ground shall be approved for extra-hard usage and shall be routed and arranged to minimize the tripping hazard. Cords and cables may be covered with approved non-conductive mats. Mats shall be self-weighted to minimize movement and drape over cords and cables.

525.13 Electrical Wiring. All permanent wiring installed on or within a structure or concession trailer shall be an approved wiring method installed according to the requirements of the National Electrical Code. Wiring for an amusement ride, attraction, tent, or similar structure shall not be supported by any other ride or structure. Hollow framing spaces within a structure shall not be used as a raceway or as an enclosure for electrical equipment.

240.20 & 240.22 Overcurrent Protective Devices. Motors and lighting circuits shall have separate fuses or circuit breakers. Lighting circuits shall be protected at no more than 20 amperes. Motors shall be protected at not over 125% of full load current or shall be thermally protected. All cords, cables and equipment must be protected from overcurrent by properly sized fuses or circuit breakers.

525.31 Equipment Grounding. Equipment grounding conductors shall be run with all feeders and branch circuits. Exposed metal parts of electrical equipment shall be bonded, and if cord connected, the cord shall have a grounding conductor and grounding type attachment plug. Equipment that is listed and labeled as double insulated is permitted. All grounding conductors in an enclosure shall terminate in a common grounding bus or lugs. The equipment grounding bar or lug(s) shall be secured to the electrical enclosure with screws or bolts used for no other purpose. Approved means shall be used to connect equipment grounding conductors to enclosures. Equipment grounding conductors shall be isolated from grounded circuit conductors.



525.11 Multiple Sources of Supply. Where multiple separately derived systems or services or both supply rides, games, attractions or other structures that are separated by less than 12 feet, all sources shall be bonded to the same grounding electrode system.

525.23 Ground-Fault Circuit-Interrupter Protection. All 125-volt, single phase, 15- and 20-ampere receptacle outlets that are in use by personnel or readily accessible to the general public shall have listed GFCI protection. Manufactured cord sets incorporating listed ground-fault circuit-interrupter protection for personnel shall be permitted. Egress lighting shall not be connected to the load side of a ground-fault circuit-interrupter device.

525.3 Attractions Using Contained Volumes of Water. Attractions utilizing pools, fountains and similar installations with contained volumes of water shall be installed per applicable the requirements of NEC Article 680.

525.3 Audio Signal and Amplification Equipment. The requirements of NEC Article 640 shall apply to the wiring and installation of audio signal processing, amplification and reproduction equipment.

525.21 Portable Wiring Inside Tents. Wiring for temporary lighting, where installed inside tents and concessions, shall be securely installed and shall be protected from accidental breakage by a suitable fixture or lamp-holder with a guard. Overhead lighting may be installed with approved Type SO cord sets. Festoon lighting or cord sets shall be installed at least 10 feet above ground where accessible to the public.

525.5 Overhead Clearances. A clearance of 15 feet in any direction shall be maintained from overhead conductors operating at 600 volts or less and any portion of an amusement ride or attraction. No portion of an amusement ride or attraction may be located under or within 15 feet horizontally of conductors operating at over 600 volts.

525.22 Receptacles. Receptacle outlets shall have the proper rating for the circuit amperes, voltage, and number of phases. All receptacles shall be grounded by an equipment grounding conductor installed with the circuit conductors. Unless otherwise protected from the weather, receptacles and switches used outdoors must have weatherproof covers. The grounding prong shall only be used for grounding. Cord and cable plugs and receptacles shall not lie on the ground. Where single-pole separable connectors are used, they shall comply with 530.22.

445.13 Generators. Generators or other power supply units and the associated electrical distribution cords and panelboards must be inspected at each engagement during the season. The conductors from the generator terminals to the first overcurrent device shall not be less than 115 percent of the nameplate rating of the generator. To establish ground, the neutral terminal in the service equipment, transformer truck, or generator shall be connected to an approved grounding electrode system with a stranded copper grounding electrode conductor sized not smaller than 4 AWG. This conductor shall be installed without splice from the grounding terminal to the grounding electrode shall be connected with approved clamps.

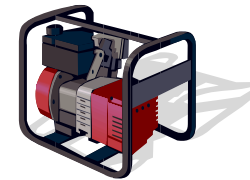

Generators that supply only loads connected directly to receptacle outlets mounted on the generator and where the equipment grounding terminals of the receptacles are bonded to the generator frame shall not be required to be connected to a grounding electrode system. All 125-volt, single phase, 15- and 20-ampere receptacles shall be GFCI-protected.

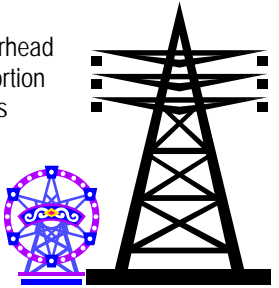

NOTE: *This information is not intended to be your only electrical information resource. Additional information and knowledge are necessary for an electrical installation that complies with the National Electrical Code and is free from fire and electric shock hazards.*

FREQUENTLY ASKED QUESTIONS

1. What is the responsibility of the Department of Labor & Industry?

The Department has the responsibility for inspection of all electrical wiring and equipment for transient events such as carnivals, circuses, festivals, production sites and road construction projects. Portable generators and distribution shall be inspected at each setup. Each ride, concession or similar unit shall be inspected at or before its initial operation each season. Equipment shall be in compliance before it is energized and put into use.

2. What is the responsibility of the user?

Users of portable power systems are responsible for notifying the department or the inspector sufficiently in advance to permit completion of the inspection, the correction of code violations, and re-inspection if necessary.

3. Is inspection of equipment necessary before the unit can be energized or used?

Equipment shall not be energized until it has been inspected and approved.

4. Does the Department of Labor & Industry perform electrical inspections in all areas of the state?

Our inspectors make electrical inspections statewide, except in cities that have made provisions electrical inspections within their jurisdiction. A list of all electrical inspectors and contact information is available at the website, www.electricity.state.mn.us.

5. How do I request an electrical inspection?

The request for electrical inspection form is completed and the appropriate inspection fee collected at the time of the inspection.



6. Do I need an inspection every year?

An initial inspection is required at or before the first setup each season. Portable generators with distribution shall be inspected at each setup.

7. Can the inspection be requested and made before the first appearance of the season?

Inspections of concession trailers can be arranged in advance by contacting the local inspector directly or the Department of Labor & Industry. Inspections can be made at any mutually agreeable time and location.

8. What if there are code violations?

Identified code violations are documented on an inspection report form and a copy is provided to the user of the equipment. Equipment shall be in compliance before it is energized and put into use.

9. Are there restrictions about who can do electrical work?

The installation, repair and correction of code violations of all on-site electrical wiring shall be done by licensed electrical contractors. Owners are not allowed to do any electrical wiring once the equipment is on-site. Persons other than licensed employees of electrical contractors are limited to plugging portable equipment into receptacle outlets.



10. How is the equipment marked to indicate that it has passed inspection?

When equipment is in compliance, an inspection sticker is placed on the equipment with the date of inspection and the inspection number. The owner's copy of the inspection form is another record of compliance, which should be kept with the equipment for the remainder of the season.

11. Are special inspections required for amusement rides?

Amusement rides must be inspected by a level II or III AIMS or NAARSO certified amusement ride inspector in the same calendar year and prior to July 1st or the first operation in Minnesota, whichever is later.

12. How much does an electrical inspection cost?

The inspection fee for each generator or source of supply is:

0 to 400 amp capacity	\$35
401 to 800 amp capacity	\$60
Above 800 amp capacity	\$100

In addition to the generator inspection, there shall be an inspection of all feeders and distribution equipment at each setup. This fee is at the \$80 hourly rate with a one-hour minimum charge.

The inspection fee for each amusement ride, device, concession, attraction, or similar unit with a supply up to and including 60 amperes is \$35.

The fee for inspection of a unit with a supply over 60 amperes is \$40.

In addition to the above fees, inspections made on Saturdays, Sundays, holidays, or after regular business hours will be charged at the \$80 hourly rate with a one-hour minimum charge.

If re-inspection of corrections is necessary, there is a \$35 charge for each re-inspection.

Inspection fees must be paid by check. Cash and credit cards are not accepted.

This diagram shows an example of an acceptable disconnecting switch for a typical concession unit.

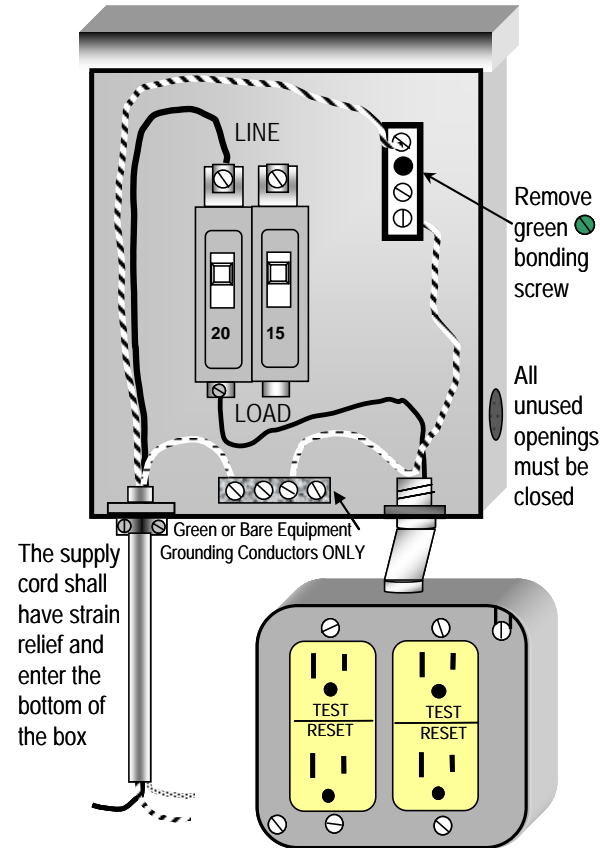

The disconnect may be permanently installed within a concession stand or mounted to a portable backboard.

The disconnect switch must be mounted in the upright position and shall be rainproof if exposed to weather.

The 120 volt, 15 and 20 amp receptacles must have ground-fault circuit-interrupter protection for personnel.

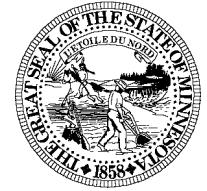

www.electricity.state.mn.us

Requirements for Portable & Temporary Electrical Power Distribution

This brochure contains important information regarding electrical licensing, electrical inspection, and the requirements of the National Electrical Code for carnivals, circuses, fairs, festivals, and similar transient projects that employ portable or temporary electrical power distribution.

443 Lafayette Road North
Saint Paul, Minnesota 55155-4342
Voice 651-284-5026
Fax 651-284-5749
TTY 651-297-4198
Toll Free 1-800-DIAL-DLI
800-342-5354